

**diytube**  
stereo 35 power amplifier

rev d

**INSTRUCTIONS FOR  
ASSEMBLY  
OPERATION**



**Price \$10.00**

## Disclaimer

Under no circumstances does diytube assume liability or responsibility for injury or damages sustained in the assembly, test or operation of this kit or for damages to any other equipment connected to it. As this is a partial kit, proper assembly is buyer's responsibility. diytube reserves the right to make design changes or improvements without the obligation to revise prior versions. All specifications are subject to change without notice.

- WARNING: Lethal voltages (greater than 400VDC) are present in this project.
- Use a Variac or isolation transformer while working on and testing the unit.
- Use a rubber mat to stand on while working on and testing the unit.
- Keep one hand in your back pocket if probing voltages with a DMM.
- Wrap a small piece of electrical tape around the test lead probe shaft to expose just the tip.
- Do not connect or disconnect wires to the terminal blocks when unit is powered or plugged in.
- Lethal voltages exist in the capacitors even after unit is powered down, so wait at least one hour to after unplugging to allow charge to dissipate.

## Warranty Information

All goods purchased from diytube have a thirty (30) day warranty from the date of purchase against defects.



"Welcome to the first meeting of guys who thought they could fix old television sets."

I strongly suggest you completely read this manual before you turn on your iron or get out the cutting oil.

## Preparation

Before assembly, some preparation needs to be done. Parts must be purchased, a work area needs to be set up and chassis decisions should be made. The axiom haste makes waste has never been more true. Make sure your chosen transformers and the board will fit comfortably using the chassis of your choice. The PCB itself makes a perfect template, as shown on the website, for socket and mounting holes. Be sure to plan where RCA connectors, binding posts, standby & ON/OFF switches and the AC cord will be oriented on the chassis. Physically lay out the parts in a space equal to your chassis to assure everything fits. Also, **note that the vacuum tube sockets can only be mounted on one side, which is designated in the silkscreen.**

## Overview of the Schematic and Design

The design closely resembles the Dynaco Stereo 35. The use of one 12DW7 per channel has been replaced by  $\frac{1}{2}$  a 12AX7A and  $\frac{1}{2}$  a 12AU7. The 12AX7A is a voltage amplifier that directly drives the 12AU7, a cathodyne phase splitter. The only other meaningful change is the replacement of a single cathode resistor and capacitor with four individual resistors and capacitors. A larger value resistor in series with a variable resistor parallels the main cathode resistor, providing a range of 320-450 ohms per cathode. This circuit is then in series with a 10 ohm resistor to calculate the current very easily via a test point - set conservatively for 350mV, thus 35mA.

## Using the Assembly Drawing

The assembly drawing is a quick reference to what component is where and the numbering scheme for the connectors. It is also a good place to make any notes.

## Soldering

This PCB is a double-sided, plated through-hole design on .094" FR4 material with LPI (liquid photo-imagable) solder mask and 2 ounce copper per side. When soldering these components, let the solder flow through the hole to form a 'teepee' on both sides of the board for an optimum connection. Ground plane connections sink a lot of heat from the soldering iron, so take care to do these well- you may have to touch up from the opposite side.

### TIP: PCB Stuffing

Use the flat end of the 10-pole terminal block as a lead bending tool. This works for most of the parts. Do take care to not damage the meniscus of the components. Insert all resistors before soldering, bending the leads down to hold them in place. This allows one to fix any placing errors that might occur very easily. Use a good pair of snips to remove the excess leads. The top side of the PCB is designated as the side with the ground plane and with the sockets marked as 'THIS SIDE ONLY'.

1. Stuff all fixed value resistors into the PCB. Mount R36 and R34 on the opposite side of the PCB (i.e. opposite of R37 and R35). This is to maximize heat dissipation.
2. Stuff variable resistors. You may choose to put them on the top side of the PCB and drill extra holes in your chassis for external adjustments. There are guide holes in the PCB for this. Also, be sure you will be able to easily insert a DMM probe between the resistors.
3. Kink leads on the silver mica capacitors and stuff.
4. Stuff D1 and D2. Mind the orientation of the cathode, which is represented by a stripe on both the silkscreen and the diode's body.
5. Stuff C5, C6, C7 & C8. Mind the polarity. The board has "+" symbols to show where the positive terminal from the capacitor should be placed. Note that many modern caps have only the "-" terminal marked, usually with a stripe running down one side. If you choose to substitute, the diameter must be no more than 10mm. Use a smaller value, for example 100uF, if necessary.
6. Stuff all the polyprop capacitors.
7. Place and solder all the tube sockets – make sure they are mounted to the non-silkscreened side. It is recommended to use an old miniature nine pin tube to break in the sockets. I have found a very small nail works well for me – but don't break the ceramic!
8. Place and solder the terminal blocks. Do not over solder the connectors as solder could then spill under the connector causing a short.
9. Stuff R42, the IRCL, making sure it doesn't lean on or touch the J1 terminal block as it gets warm.
10. Stuff the 4 filter capacitors. Mind the polarity. If these are substituted, the diameter must be 25mm or less. The height must be 30mm or less to fit in a 2" high chassis.
11. Carefully go over your work, looking for:

- a. any cold solder joints (these will look dull)
- b. solder splashes and shorts between socket pins
- c. any connections that solder didn't flow to the other side (like ground plane connections)
- d. snip excess leads
- e. compare your board to photos from the website – a good check for capacitor orientation

### Initial Impedances: When it Doubt, Ohm it Out

These are without connections to the terminal blocks. When connected, those readings that will differ will be in brackets. Different transformers will have different readings – this one is a PA-774.

J1

- |     |       |      |
|-----|-------|------|
| 1.  | >2M   | [94] |
| 2.  | >2M   | [94] |
| 3.  | >200K |      |
| 4.  | >200K |      |
| 5.  | GND   |      |
| 6.  | GND   |      |
| 7.  | 100   | [50] |
| 8.  | 100   | [50] |
| 9.  | >10M  |      |
| 10. | >10M  |      |

J2

1. >10M
2. >10M
3. GND

J3

- |    |       |         |
|----|-------|---------|
| 1. | >10M  |         |
| 2. | >10M  |         |
| 3. | 28.3K | [1 ohm] |

J4

- |    |       |         |
|----|-------|---------|
| 1. | >10M  |         |
| 2. | >10M  |         |
| 3. | 28.3K | [1 ohm] |

J5

1. >10M
2. >10M
3. GND

J6

1. >10M
2. GND

J7

1. >10M
2. GND

## Initial Settings: Feedback and Bias

**WARNING:** Do these adjustments with the unit off and unplugged, as well as having had one hour to bleed voltage from the filter caps.

Note: Most amps will just use a fixed resistor here, but the diytube circuit uses a pot for experimentations sake - thus this extra step.

- 1) Don't have your negative feedback connected yet, that is your output secondary or else it will be a real low impedance.
- 2) Probe your DMM from J4 pin 3 (right channel) to ground and adjust R30 until the resistance is 20.3K (set to 28.3K if using the 16 ohm tap as feedback, as in the original Z565).
- 3) Probe your DMM from J3 pin 3 (left channel) to ground and adjust R31 until the resistance is 20.3K (set to 28.3K if using the 16 ohm tap as feedback, as in the original Z565).
- 4) Your feedback is set.

## Adjusting Bias

- 1) With the unit off, probe your DMM from V3 pin 3 (the cathode) to ground. Adjust R22 until you measure 400 ohms to ground.
- 2) Then probe your DMM from V4 pin 3 (the cathode) to ground. Adjust R19 until you measure 400 ohms to ground.
- 3) Then probe your DMM from V5 pin 3 (the cathode) to ground. Adjust R28 until you measure 400 ohms to ground.
- 4) Then probe your DMM from V6 pin 3 (the cathode) to ground. Adjust R25 until you measure 400 ohms to ground.

**WARNING:** The following is done while the unit is ON and IDLE. Take care and follow proper high voltage safety rules.

- 5) With all your connections in place, power up. Your initial bias has been set - this makes sure that you don't accidentally have a tube aggressively biased, and they should all end up near the same range on power up.
- 6) Probe your DMM (set to DC volts) from the test point which is sandwiched between the R19 & R22 to ground. V3 is adjusted with the 'inside' test point. Adjust R22 until the voltage is .350V or 350mV.

- 7) Probe your DMM (set to DC volts) from the test point which is sandwiched between the R19 & R22 to ground. V4 is adjusted with the 'outside' test point. Adjust R19 until the voltage is .350V or 350mV.
- 8 ) Probe your DMM (set to DC volts) from the test point which is sandwiched between the R25 & R28 to ground. V5 is adjusted with the 'inside' test point. Adjust R28 until the voltage is .350V or 350mV.
- 9) Probe your DMM (set to DC volts) from the test point which is sandwiched between the R25 & R28 to ground. V6 is adjusted with the 'outside' test point. Adjust R25 until the voltage is .350V or 350mV.

## Voltages

These are zero-signal, nominal measurements in VDC, unless otherwise noted. They are all referenced to ground.

PIN	V1	V2	V3	V4	V5	V6
1	116	207	-	-	-	-
2	0	116	0	0	0	0
3	780mV	120	13	13	13	13
4	3.1VAC	3.1VAC	3.1VAC	3.1VAC	3.1VAC	3.1VAC
5	3.1VAC	3.1VAC	3.1VAC	3.1VAC	3.1VAC	3.1VAC
6	115	208	-	-	-	-
7	0	114	360	360	360	360
8	780mV	118	-	-	-	-
9	3.1VAC	3.1VAC	364	364	364	364

## Modifications

- If volume controls are desired, use a 100k or better audio taper pot. A linear pot will not work correctly. You can salvage the 250k pot off of your Dynaco SCA-35. Radio Shack has a 100k Alps stereo pot that many people use. Each channel must have its own control, so either a stereo pot or two single pots must be used.

The pot connections will be:

- pin 1 to RCA audio IN
- pin 2 (the wiper) to J6-1 or J7-1 (depending on channel)
- pin 3 to J6-2 (GND) or J7-2 (GND)

To determine which pin is which, use a DMM and crank the volume pot fully counter-clockwise (lowest volume setting).

Resistance between pins 1 & 2 will be nearly the full range of the pot. Pins 2 & 3 will be very low resistance. Rotating the pot fully clockwise (highest volume setting) will yield opposite results, i.e. pins 1 & 2 will be very low resistance and pins 2 & 3 will be nearly the full range of the pot. If using a stereo pot, follow the same process with pins 4, 5 & 6.

- A 100 ohm 1W resistor (Mouser# 281-100) can be soldered on the underside of the board between pins 1 & 2 on J2,J3,J4 and J5 for triode operation. Do not attach any UL taps to pin 2 on these connector blocks if you do this. Do not populate C20 & C21.
- If you are using a filament supply with a center tap and choose to use the center tap, do not populate R40 and 41. These are for non-CT filament supplies, such as the Dynaco PA-774.
- SW2 can be omitted and the secondary CT wired straight to ground if a standby switch is not desired.
- R42, the IRCL, is very important for proper operation of this unit. It is possible to wire a switch in parallel with it in order take it out of the circuit once the unit has warmed up, but this is not recommended- especially for Hammonds, as they are rated at 115VAC. Note: This will increase the B+ by around 12V and will slightly increase heater voltage. Switch would need to be reset as well.
- A .05uF, 1kV ceramic cap may strap the ON/OFF switch (pins 1 and 2). This can prevent 'pops' on turnoff.

Tip: Put a dot in the checkbox if you have the part already as a quick reference when ordering parts. 'X' out the checkbox when you have installed the part on the PCB.

<i>Item</i>	<i>QTY</i>	<i>Reference</i>	<i>Part</i>	<i>Mouser Part</i>	<i>Unit Cost</i>
<input type="checkbox"/>	2	R1,R2	47K, 1/2W	71-RN65D-F-47.5K	0.32
<input type="checkbox"/>	6	R3,R4,R13,R14, R15,R16	470K, 1/2W	71-RN65D-F-470K	0.32
<input type="checkbox"/>	2	R5,R6	1.3K, 1/2W	71-RN65D-F-1.27K	0.32
<input type="checkbox"/>	2	R7,R8	300K, 1/2W	71-RN65D-F-301K	0.32
<input type="checkbox"/>	2	R9,R10	27K, 1W	281-27K	0.13
<input type="checkbox"/>	2	R11,R12	33K, 1W	281-33K	0.13
<input type="checkbox"/>	4	R17,R20,R23,R26	470, 3W	72-RWM410-470-5	0.32
<input type="checkbox"/>	4	R18,R21,R24,R27	1K, 1/2W	71-RN65D-F-1.0K	0.32
<input type="checkbox"/>	4	R19,R22,R25,R28	10K Pot	72-T93YB-10K	1.20
<input type="checkbox"/>	1	R29	300K, 1W	294-300K	0.14
<input type="checkbox"/>	2	R30,R31	100K Pot	72-T93YB-100K	1.20
<input type="checkbox"/>	2	R32,R33	3.3K, 3W	72-RWM410-3K3-5	0.46
<input type="checkbox"/>	4	R34,R35,R40,R41	100, 3W	72-RWM410-100-5	0.32
<input type="checkbox"/>	2	R36,R37	.05, 3W	71-LVR3-0.05/R	1.20
Note: Use the 0.025 ohm instead when using a PA774 - Mouser# 71-LVR3-0.025/R					
<input type="checkbox"/>	2	R38,R39	150K, 1/2W	71-RN65D-F-150K	0.32
<input type="checkbox"/>	1	R42	Inrush Limiter	527-CL90	2.35
<input type="checkbox"/>	4	R43,R44,R45,R46	10 Ohm, 1/4W	71-RN60D-F-10	0.21
<input type="checkbox"/>	4	C1,C2,C3,C4	0.1uF,400V	75-715P400V0.1	0.98
<input type="checkbox"/>	4	C5,C6,C7,C8	470uF	140-XRL35V470	0.21
<input type="checkbox"/>	4	C9,C10,C11,C12	120uF	5985-380-450V121	2.79
<input type="checkbox"/>	2	C16,C17	27pF	5982-15-500V27	0.55
<input type="checkbox"/>	2	C18,C19	33pF	5982-15-500V33	0.55
<input type="checkbox"/>	2	C20,C21	15pF	5982-15-500V15	0.53
<input type="checkbox"/>	2	C22,C23	0.22uF	5989-250V.22	0.31
<input type="checkbox"/>	2	D1,D2	UF4007 Diode	625-UF4007	0.25
<input type="checkbox"/>	1	J1	10pin .375" Block	571-114376644	1.82
<input type="checkbox"/>	4	J2,J3,J4,J5	3pin .375" Block	571-14376645	0.82
<input type="checkbox"/>	2	J6,J7	2pin .375" Block	571-14376644	0.61

**diytube Stereo 35 Rev D****Revised: May 16, 2004**

<i>Item</i>	<i>QTY</i>	<i>Reference</i>	<i>Part</i>	<i>Mouser Part</i>	<i>Unit Cost</i>
-------------	------------	------------------	-------------	--------------------	------------------

Note: Change the last letter of the part number, 'G', to a 'Y' or 'R' for a yellow or red neon indicator on the power switch. Default is green.

<input type="checkbox"/>	1	SW1	Power Switch	103-R13-112B-02G	1.29
<input type="checkbox"/>	1	SW2	Standby Switch	103-R13-112A-02	0.99
<input type="checkbox"/>	1	F1	Fuse Holder	504-HTB-26M	2.13
<input type="checkbox"/>	1	F1	2A Midget Fuse	504-GMA-2	0.26
<input type="checkbox"/>	1		3-Prong AC cord	173-53101	2.80
<input type="checkbox"/>	1		Strain Relief	561-MP5N4	0.10
<input type="checkbox"/>	1		Stereo Volume Pot	313-2420-100K	2.35

Note: Hammond product is very inexpensive at [www.angela.com](http://www.angela.com)

<input type="checkbox"/>	1		12X8X2 Chassis	546-1444-22	20.22
<input type="checkbox"/>	1		12X8 Bottom	546-1434-22	8.66
or					
<input type="checkbox"/>	1		12X10X2 Chassis	546-1444-29	20.35
<input type="checkbox"/>	1		12X10 Bottom	546-1434-29	8.66

Note: These aren't \$30, gold-plated interconnects. Due to the small quantities of nuts & bolts, you might want to buy these at your local hardware store. The Mouser parts are nickel plated and in boxes of 100. Don't forget solder, spade connectors, etc.

<input type="checkbox"/>	1		RCA Red Jack	161-0251	0.87
<input type="checkbox"/>	1		RCA Black Jack	161-0252	0.87
<input type="checkbox"/>	4		Binding Posts	164-4205	1.29
<input type="checkbox"/>	2		Binding Posts	164-4201	1.29
<input type="checkbox"/>	2		Red Test Points	151-307	0.28
<input type="checkbox"/>	2		White Test Points	151-301	0.28
<input type="checkbox"/>	8		Standoffs 1/4X1/2	534-1451C	0.45
<input type="checkbox"/>	6		Bushings	534-744	0.49
<input type="checkbox"/>	1 box (need 16)		6-32x1/4 screws	5721-632-1/4	1.77
<input type="checkbox"/>	1 box (need 8)		#6 lock washers	5721-LWI-6	1.57
<input type="checkbox"/>	1 box (need 12)		10-32x3/8 screws	5721-1032-3/8	2.95
<input type="checkbox"/>	1 box (need 12)		#10 flat washers	538-MW-404C	2.00
<input type="checkbox"/>	1 box (need 12)		#10 lock washers	5721-LWI-10	1.82
<input type="checkbox"/>	1 box (need 12)		10-32 hex nuts	5721-1032	2.56

**diytube Stereo 35 Rev D**

**Revised: May 16, 2004**

Item QTY Reference Part Mouser Part Unit Cost

Note: I'm assuming this is the area people will improvise most, and with parts they have on hand. I highly recommend parting out a Dynaco SCA-35 as these are the same transformers found the in the highly regarded Dynaco ST-35.

- 1 V1 12AX7 varieties
- 1 V2 12AU7 varieties
- 4 V3,V4,V5,V6 6BQ5/EL84/7189/6p14p
- 6 V1-V6 9pin PCB Ceramic Socket (13/16" tail diameter)

- 1 T1 Dynaco PA-774 Power Transformer
- or
- 1 T1 Hammond 270HX Power Transformer

- 2 T2,T3 Dynaco Z-565 Output Transformer (8 & 16 ohm)
- or
- 2 T2,T3 Magnequest MQ-565 Output Transformer (8 & 16 ohm)
- or
- 2 T2,T3 Triode Electronics 4 & 8 ohm Z-565 Output
- or
- 2 T2,T3 Hammond 1650F Output Transformer

Note: Hammond 1650E (8k) and 1620 (6.6k) have been used as well.

Triode Electronics -- aka Uncle Ned <http://www.triodeelectronics.com/>  
 Angela Instruments -- <http://www.angela.com/>  
 Antique Electronics -- <http://www.tubesandmore.com/>  
 Handmade Electronics -- <http://www.hndme.com/>

<i>Triode Electronics</i>	<i>Angela Instruments</i>	<i>Antique Electronics</i>	<i>Handmade Electronics</i>
Reissue PA774 \$59.95	Hammond 270HX \$45.00	Hammond 270HX \$62.38	Hammond 270HX \$69.31
Magnequest Z565 \$99.00	Hammond 1650F \$47.00	Hammond 1650F \$55.22	Hammond 1650F \$61.36
9pin Ceramic PC \$1.95	Hammond 1441-22 \$19.00	9pin Ceramic PC \$2.50	9pin Ceramic PC \$1.95
Sovtek EL84 quad \$23.90	Hammond 1434-22 \$7.25	EI EL84 quad \$31.80	Hammond 1444-24 \$20.45
12AX7 \$5.95		12AX7 \$6.95	Hammond 1434-22 \$8.66
12AU7 \$6.95		12AU7 \$4.75	

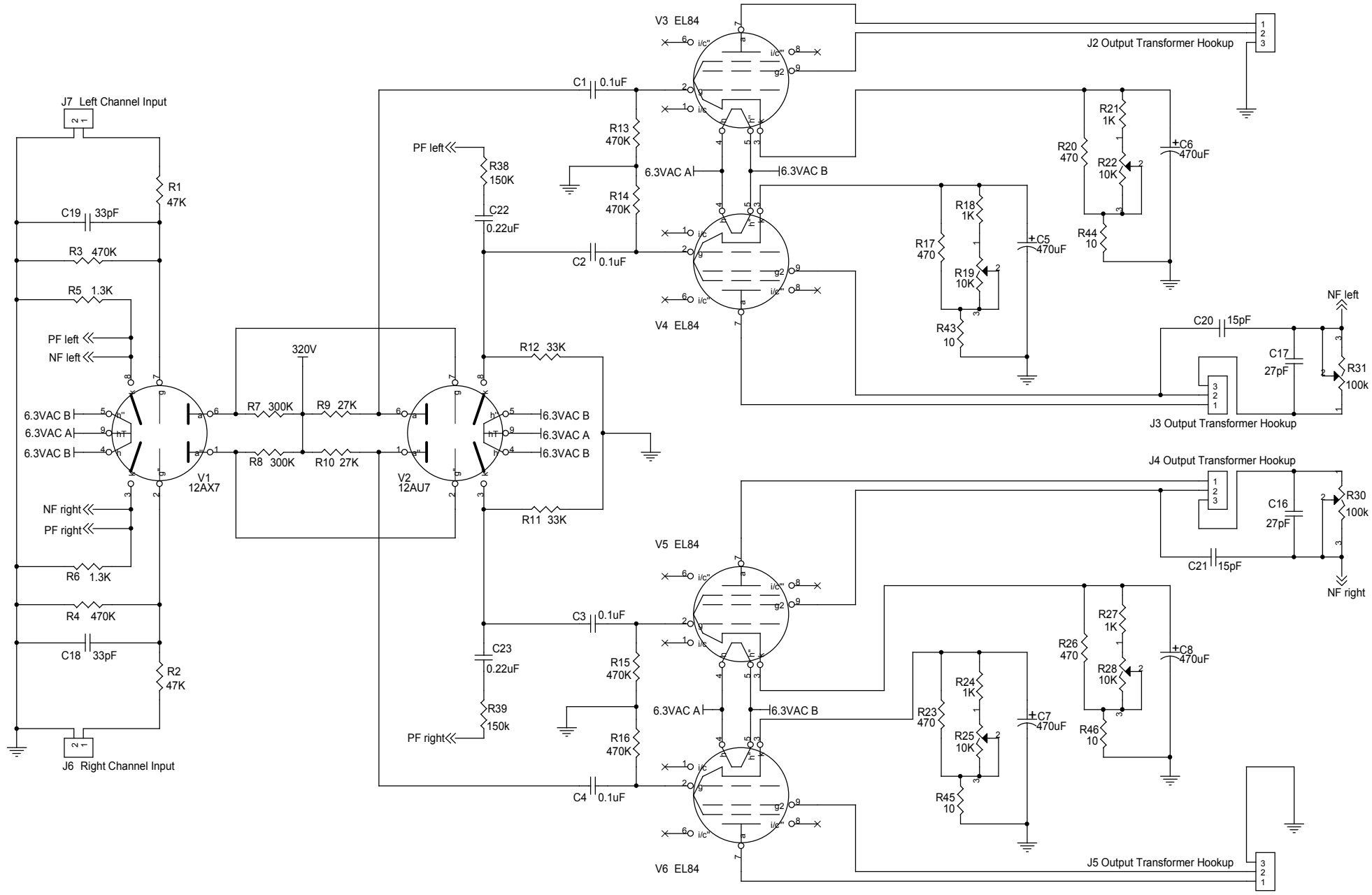

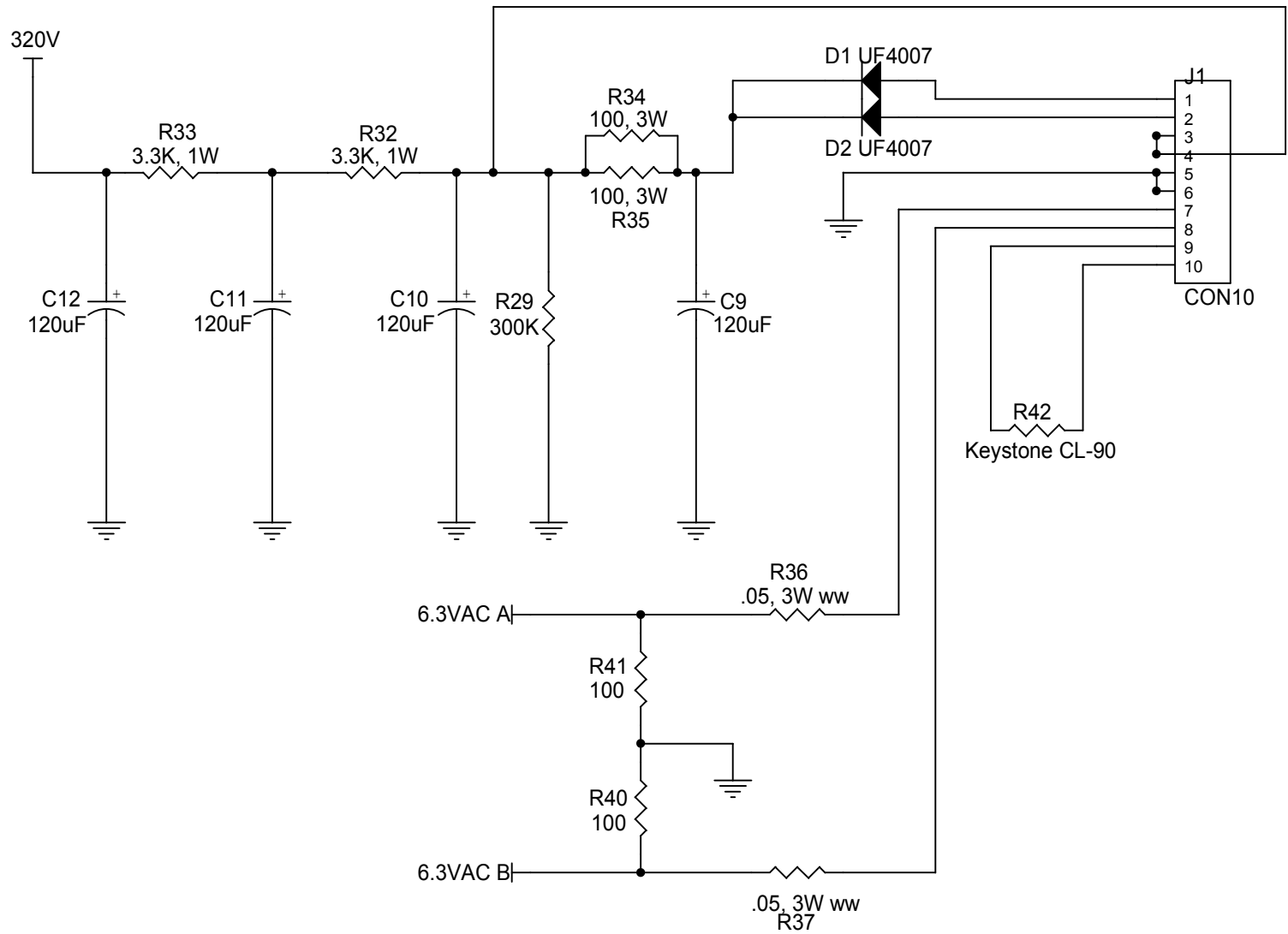

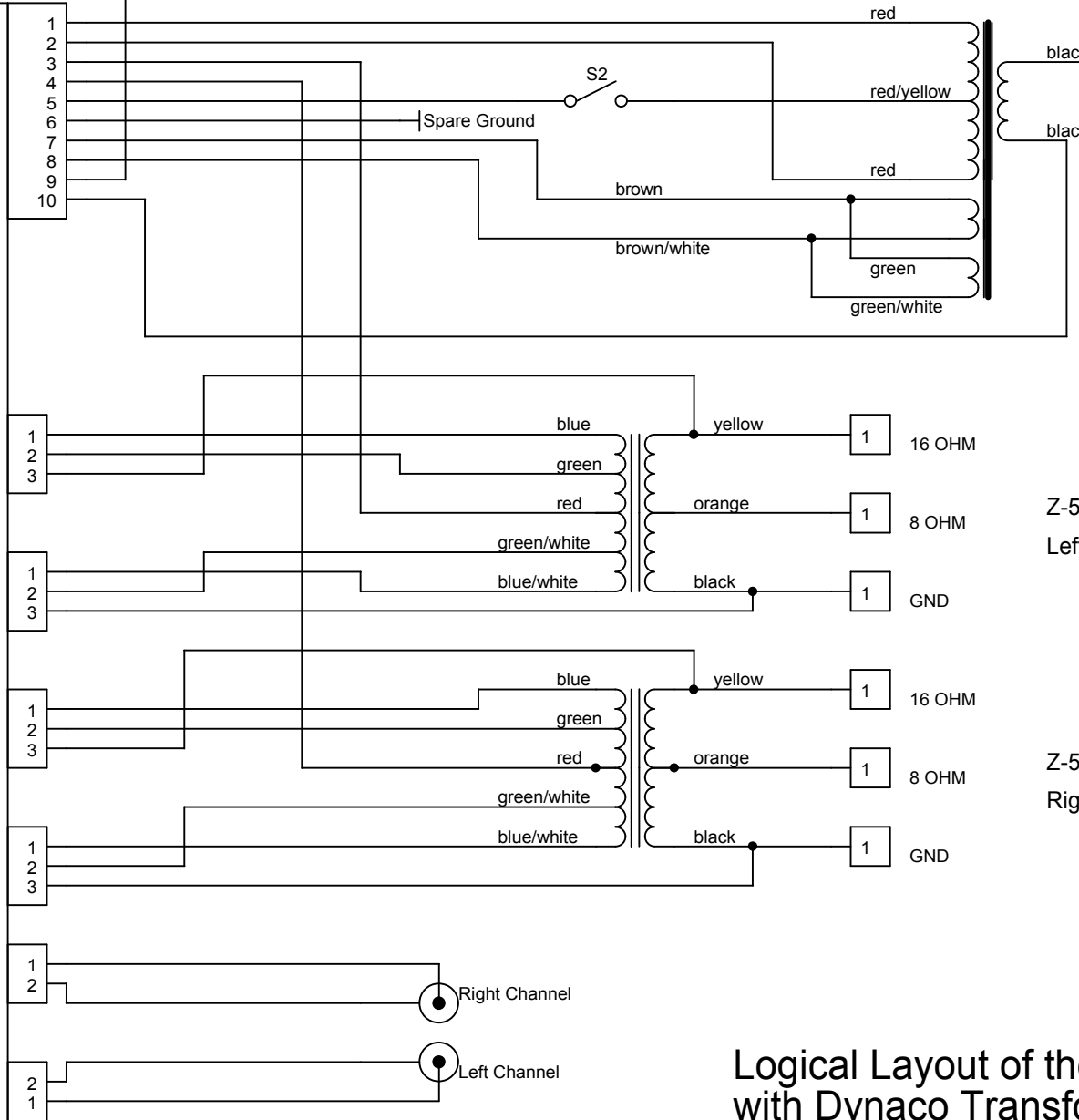
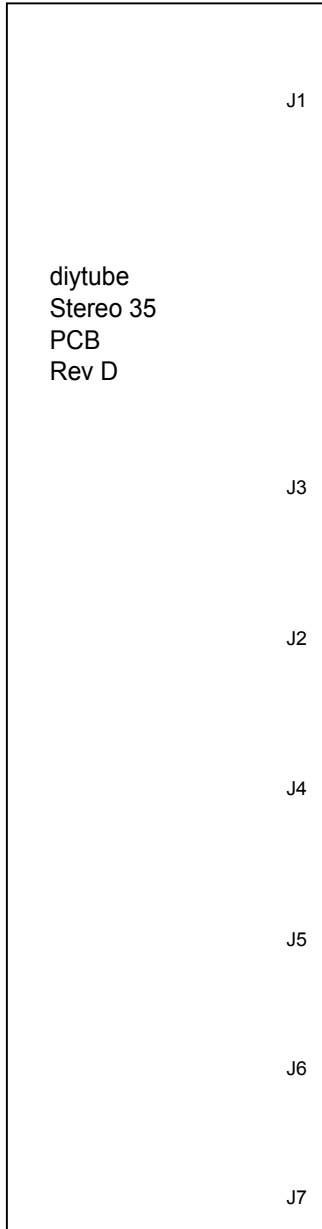
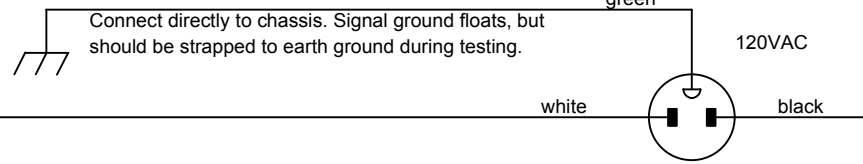

SW1:  
Connect pin 1 to the fuse,  
pin 2 to the primary and pin 3 to  
J1-10, as the neon bulb is in  
parallel to the primary winding.

PA-774  
Power Transformer

Z-565  
Left Output Transformer

Z-565  
Right Output Transformer

1 16 OHM

1 8 OHM

1 GND

1 16 OHM

1 8 OHM

1 GND

Right Channel

Left Channel

Logical Layout of the diytube Stereo 35 with Dynaco Transformers

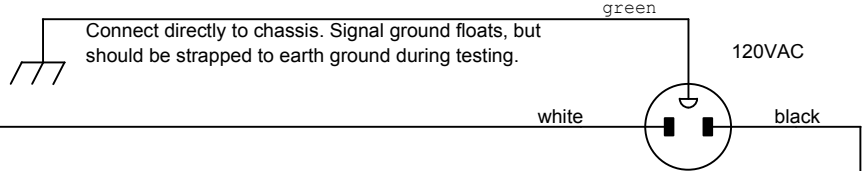

SW1:  
Connect pin 1 to the fuse,  
pin 2 to the primary and pin 3 to  
J1-10, as the neon bulb is in  
parallel to the primary winding.

Hammond 270HX  
Power Transformer

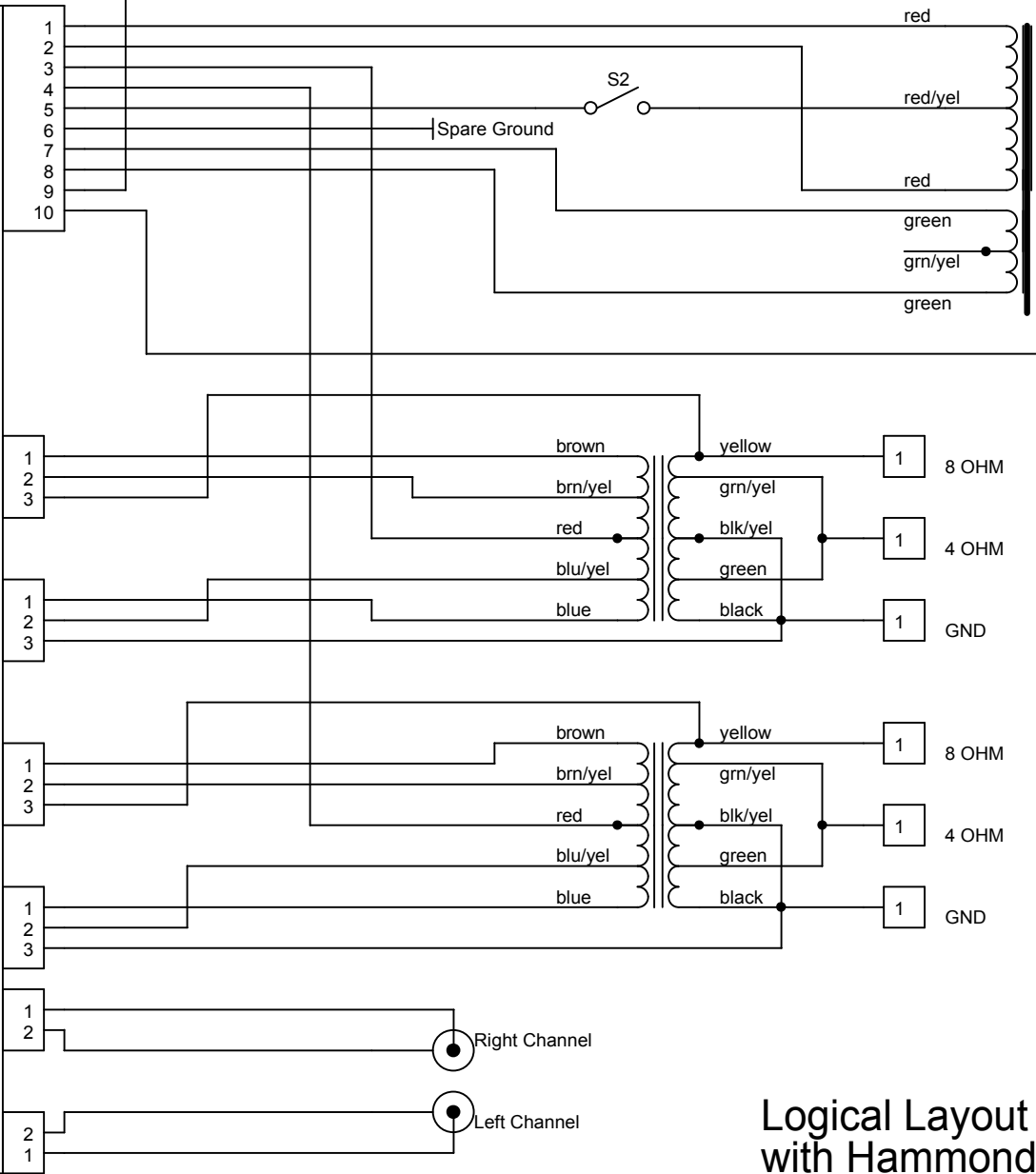
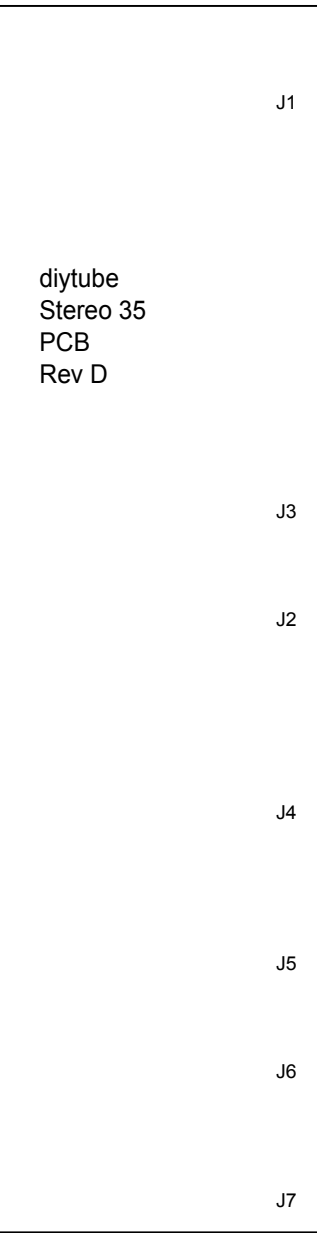

Hammond Style  
Left Output Transformer

Just think green/yellow to green, and  
black/yellow to black.

Hammond Style  
Right Output Transformer

Logical Layout of the diytube Stereo 35  
with Hammond Transformers

